



DC Ammeter Hi-Per* Shunts: TYPE THB – 400 Watts



Product Overview

- Up to 400 Watts at +25°C Case Temperature derated to zero at +125°C
- Copper Heat Dissipating Mounting Surface
- Resistance Range of: 0.0001 to 0.03 Ohms
- Maximum Current: 600 Amps
- Resistance Tolerance: $\pm 0.25\%$ or $\pm 0.10\%$
- Breakdown Voltage: 1.5 kV to 5 kV AC
- Exclusive Non-Inductive Design
- A phenolic case for environmental protection

Ordering Information:

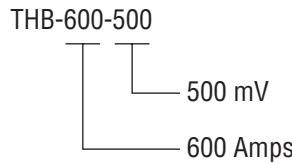

Heat sink mountable design with non-inductive performance, featuring an exposed copper heat dissipating mounting surface electrically insulated.

Use your thermal design experience with power semiconductors. This experience will help you get the most out of this unique family of high performance (Hi-Per*) Shunts.

The thermal design issues are the same where the power handling capability is based on the case temperature which is maintained in your design.

Resistor element is electrically isolated from the mounting metal heat sink surface.

The case temperature is to be used for the purpose of establishing the maximum applied power. *See Derating Curve.*

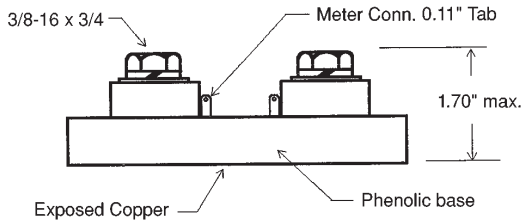
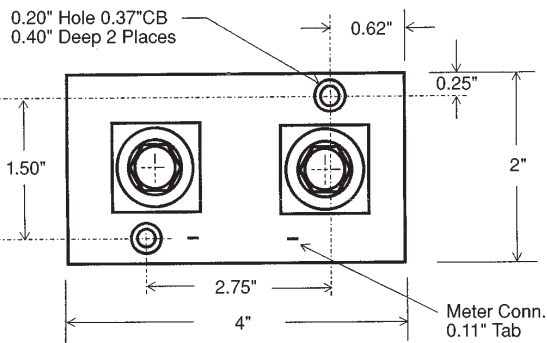

Derating Curve

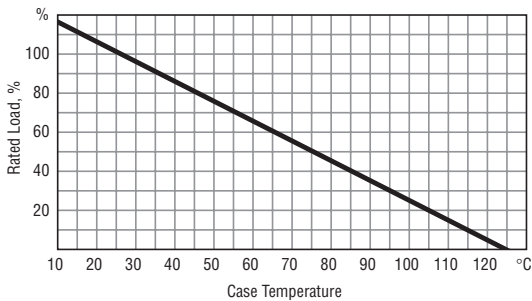

We are ready to assist you in the application of the new generation of shunts or in the design of a custom shunt product to solve your unique circuit performance requirements.