

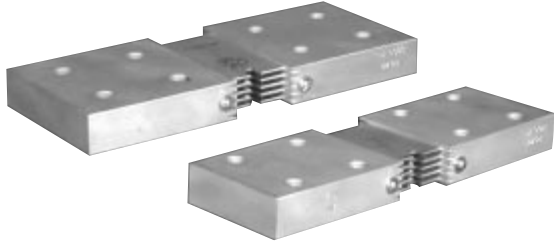

DC Ammeter Shunts

STD Accuracy $\pm 0.25\%$

TYPE A: 1,500 through 6,000 Amperes



TYPE A: 50 mV

Catalog Number	AMP	A	B	C	D	E	F	G
A-1500-50	1500	9.62	3	1	3.62	0.43	2	0.50
A-2000-50	2000	9.62	4	1	3.62	0.43	2	1
A-3000-50	3000	9.62	4	1.50	3.62	0.56	2	1
A-4000-50	4000	9.62	5	1.50	3.62	0.56	2.50	1.25
A-5000-50	5000	9.62	5	1.50	3.62	0.56	2.50	1.25
A-6000-50	6000	9.62	5	2	3.62	0.56	2.50	1.25

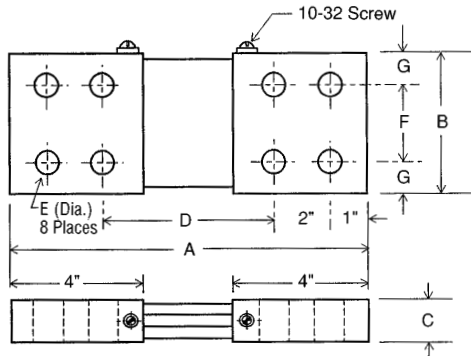

TYPE A: 100 mV

Catalog Number	AMP	A	B	C	D	E	F	G
A-1500-100	1500	11.25	3	1	5.25	0.43	2	0.50
A-2000-100	2000	11.25	4	1	5.25	0.43	2	1
A-3000-100	3000	11.25	4	1.50	5.25	0.56	2	1
A-4000-100	4000	11.25	5	1.50	5.25	0.56	2.50	1.25
A-5000-100	5000	11.25	5	1.50	5.25	0.56	2.50	1.25
A-6000-100	6000	11.25	5	2	5.25	0.56	2.50	1.25

Tolerances $\pm .015$ for the hole diameters. Other tolerances $\pm .030$ unless specified.
Dimensions subject to change without notice.